

EXCALIBUR

EXTRUSIONS

Flexible PVC

NIPPLES

Brown

Excalibur Hose ASTM D-2287
Cell #6464500 Meets or Exceeds Cell #5360500
Patent #3,759445

Part Number	Pipe Size	Overall Length	Type of Fittings	Quantity Per Box	Weight Per Box	List Price
506 MM	1/2"	6"	MAxMA	100	15	2.32
506 MF	1/2"	6"	MAxFA	100	15	2.49
506 FF	1/2"	6"	FAxFA	100	15	2.59
506 ME	1/2"	6"	MAx90 ELL	100	19	2.63
506 MS	1/2"	6"	MAxST ELL	100	18	2.84
506 SS	1/2"	6"	STxST ELL	100	19	3.93
512 MM	1/2"	12"	MAxMA	100	30	2.84
756 MM	3/4"	6"	MAxMA	50	11	3.20
756 MF	3/4"	6"	MAxFA	50	11	3.40
756 ME	3/4"	6"	MAx90 ELL	50	14	3.48
756 MS	3/4"	6"	MAxST ELL	50	13	4.10
756 SS	3/4"	6"	STxST ELL	50	14	4.37
712 MM	3/4"	12"	MAxMA	50	22	4.06
1007 MM	1"	7"	MAxMA	50	18	4.18
1007 MF	1"	7"	MAxFA	50	18	4.38
1007 ME	1"	7"	MAx90 ELL	50	21	4.73
1007 MS	1"	7"	MAxST ELL	50	20	5.98
1012 MM	1"	12"	MAxMA	50	27	5.17

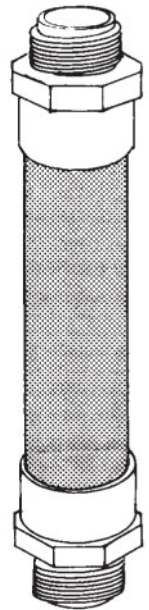

Special Flexible PVC Nipples

Special nipples can be made in any length or with any combination of fittings so desired in minimum quantities of 50 or more of each item. Contact your Distributor or Factory for details.

For longer lengths use special nipple discount for item desired and add the following net cost per inch to your net cost.

1/2" - Add .036 Net/Inch

3/4" - Add .058 Net/Inch

1" - Add .088" Net/Inch

INSTALLATION

EXCALIBUR

EXTRUSIONS

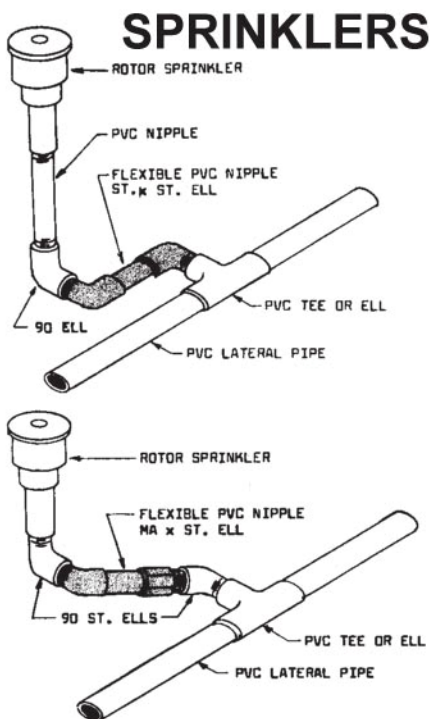
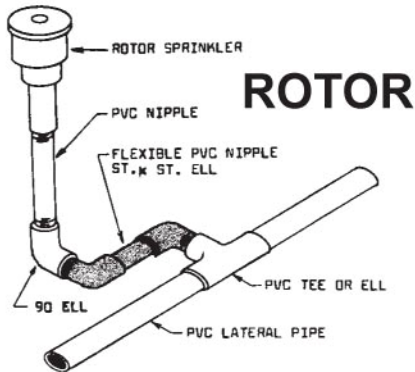

SPECIFICATIONS:

For 1/2", 3/4" & 1" Flexible PVC Nipples. Check factory for availability of sizes 1-1/4" & 1-1/2". Made from all virgin PVC materials. Flexible hose complies with ASTM D2287. Schedule 40 fittings complies with ASTM D2466. Tested at 200 psi static pressure for 2 hours. Quick burst test exceeds 400 psi.

INSTALLATION INSTRUCTIONS:

1. If the system is to be pressure tested this must be done before installation of the flexible nipples or damage to the nipples could result.
2. Do not install under constant static pressure conditions such as under quick couplers or valve in head sprinklers.
3. When installing sprinkler heads on flexible nipples be sure to hold the nipple with a wrench so that the nipple is not twisted when tightening heads.

POP-UP OR FLUSH SPRINKLERS

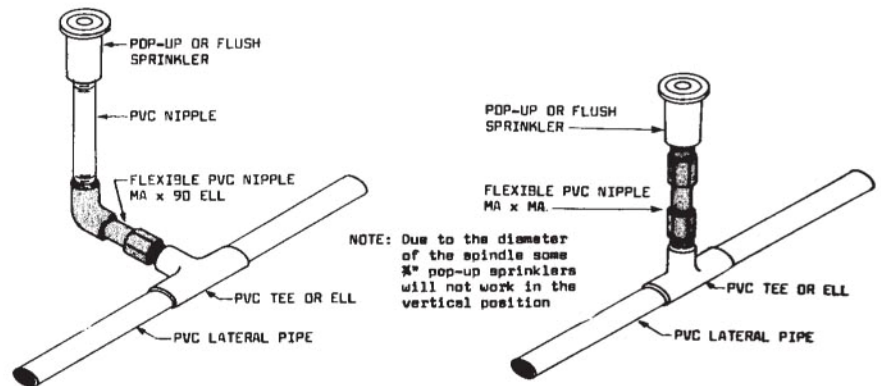

IMPACT SPRINKLERS

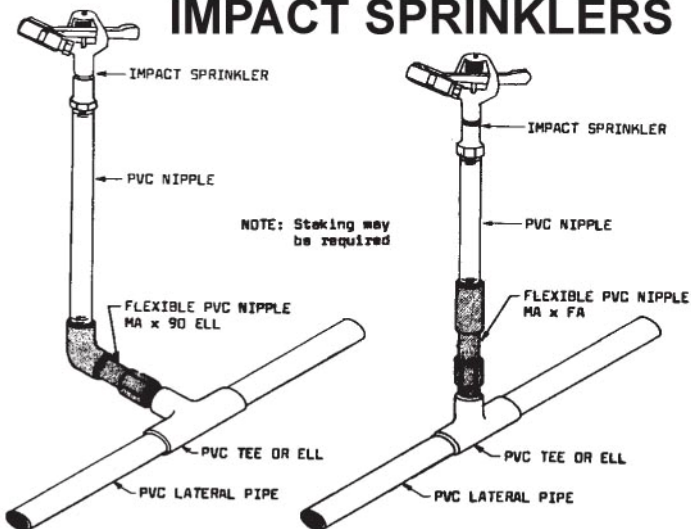

SHRUB SPRINKLERS

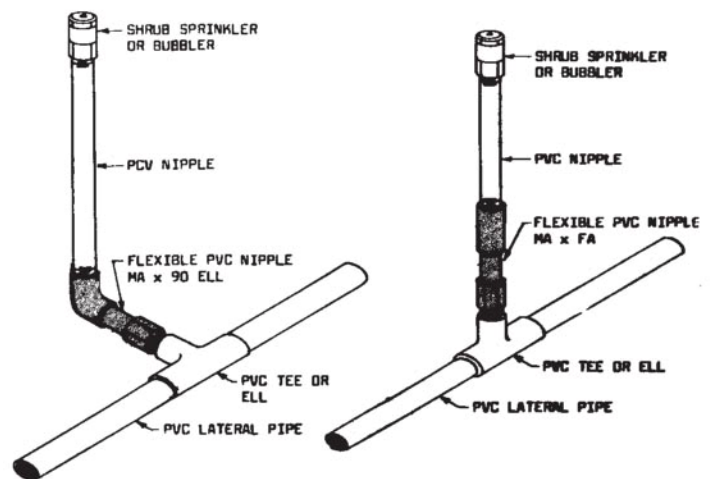

EXCALIBUR

EXTRUSIONS

Extra Flexible PVC NIPPLES

White

Patent #3,759,445

Pt. No.	Pipe Size	Overall Length	Type of Fitting	Quantity Per Box	Weight Per Box	List
504MM-EF	1/2"	4"	MA x MA	100	11	2.13
504MF-EF	1/2"	4"	MA x FA	100	11	2.24
504FF-EF	1/2"	4"	FA x FA	100	11	2.31
504ME-EF	1/2"	4"	MA x 90 ELL	100	15	2.32
504MS-EF	1/2"	4"	MA x ST ELL	100	14	2.54
504SS-EF	1/2"	4"	ST x ST ELL	100	15	3.74
505MM-EF	1/2"	5"	MA x MA	100	13	2.32
505MF-EF	1/2"	5"	MA x FA	100	13	2.49
505FF-EF	1/2"	5"	FA x FA	100	13	2.58
505ME-EF	1/2"	5"	MA x 90 ELL	100	17	2.58
505MS-EF	1/2"	5"	MA x ST ELL	100	16	2.83
505SS-EF	1/2"	5"	ST x ST ELL	100	17	3.92

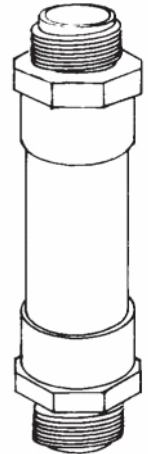

Extra Flexible PVC Nipples are made of the finest quality virgin material
Especially useful where greater flexibility is required

Flexible Rubber Nipples

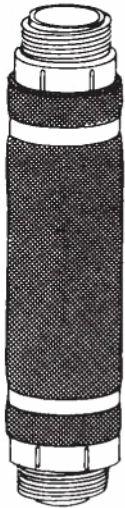

Pt. No.	Pipe Size	Overall Length	Type of Fitting	Quantity Per Box	Weight Per Box	List
R-506MM	1/2"	6"	MA x MA	100	13	2.31
R-756MM	3/4"	6"	MA x MA	50	14	5.72
R-756MS	3/4"	6"	MA x ST ELL	50	15	5.72
R-1007MM	1"	7"	MA x MA	50	19	6.42
R-1007MS	1"	7"	MA x ST ELL	50	21	6.43
R-1259MM	1-1/4"	9"	MA x MA	25	23	14.50
R-1259MS	1-1/4"	9"	MA x ST ELL	25	27	15.73
R-1511MM	1-1/2"	11"	MA x MA	25	29	18.75
R-1511MS	1-1/2"	11"	MA x ST ELL	25	31	20.57

Flexible Rubber Nipples are made of the finest synthetic rubber and are banded with stainless steel. They are impervious to acidic or alkaline soils. They are particularly useful under large turf irrigation equipment or cold weather applications.

INSTALLATION:

1. If the system is to be pressure tested this must be done before installation of the flexible rubber nipples or damage to the nipples could result.
2. Do not install under constant static pressure conditions such as under quick couplers or valve-in-head sprinklers.
3. When installing sprinkler heads on flexible rubber nipples be sure to hold the nipple with a wrench so that the nipple is not twisted when tightening heads.

Spring Back Risers®

FLEXIBLE PVC NIPPLES

EXCALIBUR

EXTRUSIONS

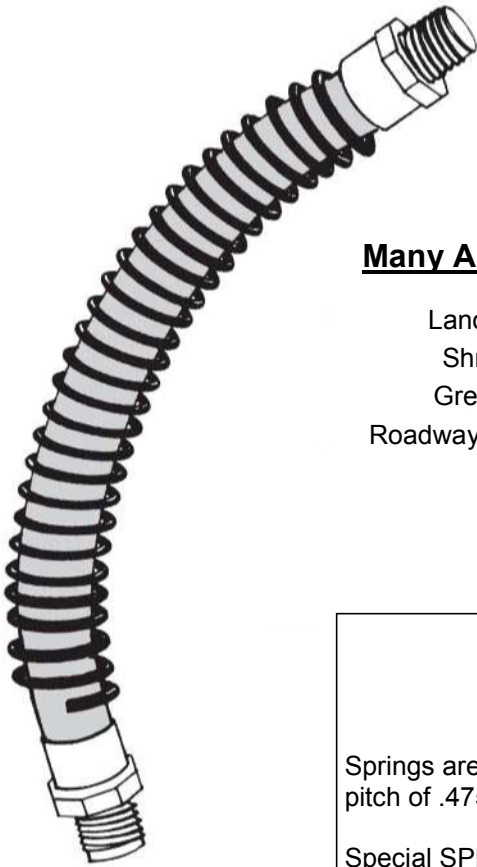

Spring Back Risers®
Springs Back To Original Position After Impact
Over 12 Years Field Tested & Approved

Many Applications

Landscaping
Shrubbery
Green Belts
Roadway Landscaping



Cuts Costs

Vandalism
Broken Pipes
Washed Out Landscaping

1/2" Heavy Wall Flex PVC Tube

Has Been Tested At Over 150 PSI

Springs are made from .187" DIA. (OTMB) Spring Wire. They have an inside DIA of .910" a pitch of .475" and have squared ends.

Special SPRING BACK RISERS® can be made in any length with any combination of fittings desired. Contact your distributor or factory for details.

5 Sizes

*As Specified for Cal. Trans. as TYPE B7

Part Number	Pipe Size	Overall Length	Spring Length	Box Quantity	List Price
SL508MM	1/2"	8"	4"	50	7.44
SL512MM	1/2"	12"	8"	50	8.58
SL516MM	1/2"	16"	12"	25	9.16
SL518MM	1/2"	18"	14"	25	9.36
SL524MM	1/2"	24"	18"	25	10.05